 <b>KLINGER</b> Schöneberg	Assembly and Repair Instructions	page 1 of 6 release 0
	INTEC K410- T-STD	file: Montage-Reparatur- Anl INTE K410 T STD- EN_22012016

## Assembly and Repair Instructions for KLINGER SCHÖNEBERG Ball Valves, Type INTEC K410-T-STD

### Table of Contents

1	Validity .....	2
2	General Remarks.....	2
3	Construction and Components INTEC K410-T-STD.....	3
4	Assembly of the INTEC K410-T-STD.....	4
4.1	Preparing for Assembly .....	4
4.2	Assembling the Valve.....	4
4.3	Function, Strength and Tightness Test.....	5
4.4	Independent Conversion and Manufacture of Spare Parts.....	5
4.5	Incorrect Operation.....	5
5	Dismantling .....	5
5.1	Precautionary Measures.....	5
5.2	Preparing for Dismantling .....	6
5.3	Dismantling.....	6
5.4	Final Cleaning and Recording of Damage.....	6

Provide: Hauck	Approval: Roth	Date: 22.01.2016
Printed pages will not be updated		

	Assembly and Repair Instructions	page 2 of 6 release 0
	INTEC K410- T-STD	file: Montage-Reparatur- Anl INTE K410 T STD- EN_22012016

## 1 Validity

These Assembly and Repair Instructions are applicable to the type series listed below:

INTEC K410-T-STD

## 2 General Remarks

These Assembly and Repair Instructions are designed to provide assistance in assembling, servicing and repairing the ball valve INTEC K410-T-STD.



The valves may only be dismantled and taken apart by skilled personnel acquainted with the assembly, commissioning and operation of this product.

Trained personnel within the meaning of these Assembly and Repair Instructions are individuals who are able to assess the work which they have been entrusted and to recognise possible risks in view of their special training, their know-how and experience and their knowledge of the pertinent standards.

These instructions as well as the **Operating Instructions for KLINGER SCHÖNEBERG Ball Valves** must be observed. KLINGER SCHÖNEBERG GmbH shall not assume no liability for damage or interruptions to operation arising from incorrect handling or failure to observe these Repair Instructions.

Provide: Hauck	Approval: Roth	Date: 22.01.2016
Printed pages will not be updated		

### 3 Construction and Components INTEC K410-T-STD

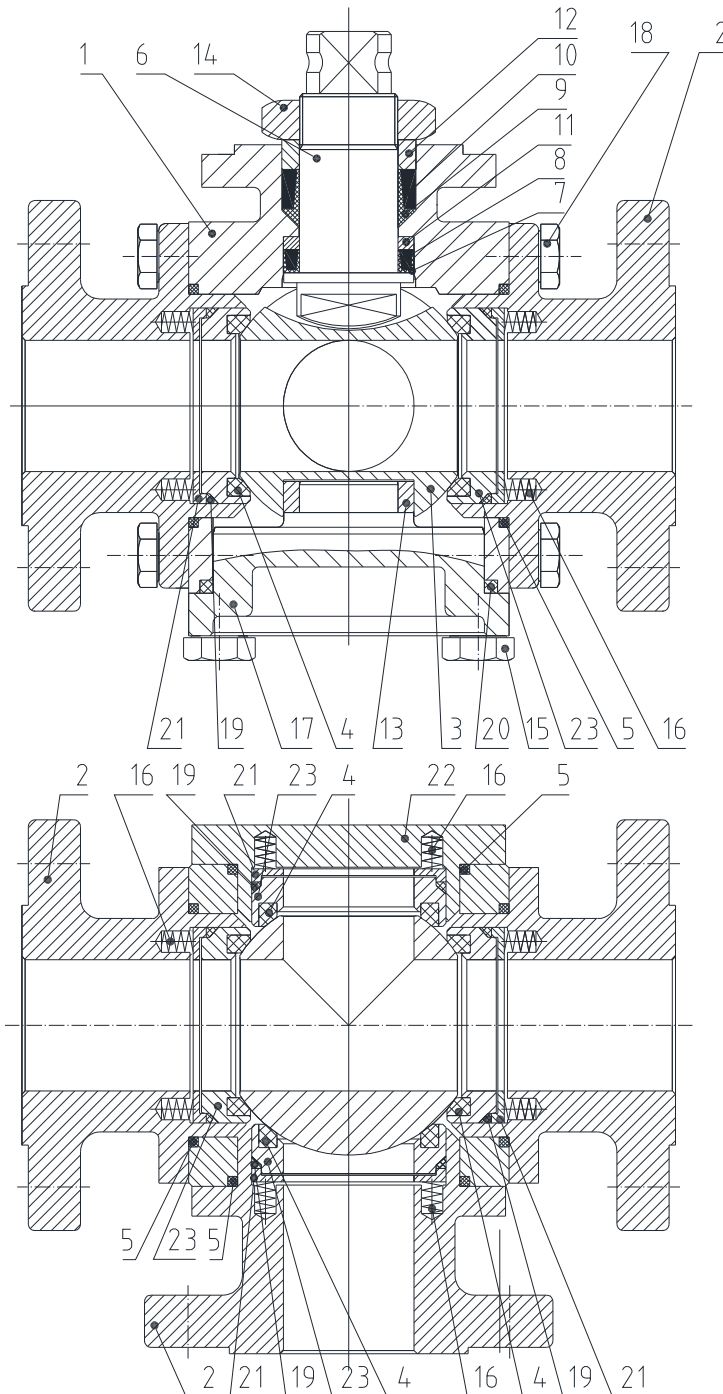

23	seat ring
22	blind cap
21	follower ring
20	trunnion seal
19	seat seal
18	hex. screw
17	trunnion
16	spring
15	hex. screw
14	hex. nut (self- locking)
13	trunnion bearing
12	upper bearing
11	below bearing
10	upper cone ring
9	upper seal
8	below cone ring
7	below seal
6	stem
5	body seal
4	seat
3	ball
2	cap
1	body
<b>Pos.</b>	<b>part</b>

 <b>KLINGER</b> Schöneberg	Assembly and Repair Instructions	page 4 of 6 release 0
	INTEC K410- T-STD	file: Montage-Reparatur- Anl INTE K410 T STD- EN_22012016

## 4 Assembly of the INTEC K410-T-STD

### 4.1 Preparing for Assembly

All parts must be prepared to assemble the ball valve, i.e. the parts are carefully cleaned and laid on a soft base (rubber mat or similar).

It must be considered that the plastic parts are almost always soft and very sensitive and that in particular the sealing surfaces may not be damaged.

### 4.2 Assembling the Valve

The body (1) of the valve must be tensioned securely and safely in a suitable device; free access to the cavity and stem must be guaranteed.

Lightly grease the body (1) and the cap (2) and blind cap (22) in the area of the seat ring (23) with high temperature grease (e.g. Q1) licensed by the FDA. Insert spiral spring (16) into cap (2) and blind cap (22). Attention: quantity of spiral springs according to the specification or resultant torque. Insert follower ring (21) and seat seal (19). Insert seat ring (4) in follower ring (21). It should be able to insert it with slight manual pressure. If it fits too tightly or too loosely the dimensions must be checked.

Slightly grease the stem (6) in the area of the below bearing (11) and below seal parts (7) (8) with high temperature grease licensed by the FDA. Similarly slightly grease the body (1) in the area of the bearing and the stem sealing. Only a light grease film should arise which does not spill out during assembly of the sealing elements. The grease may be applied with the assistance of a brush for example.

Handle graphite gaskets with more caution because the material breaks easily through strong distortion



In the case of valves stated as being oil- and grease-free the assembly should be made without grease and without other auxiliary substances.

Thread on bearing (11) and sealing parts (7) (8) to stem (6) and push on stem from the inside through the body (1). Bearing parts may not be damaged.

Thread on stem sealing parts (9) (10) (12) from the top to the stem (6). Screw on the self-locking nut (14) opened with the wedge onto the stem (6). Tighten nut with wrench.

Tighten the nut up to seated on the sealing package, rotate a ½ turn more, so the sealing package can set. Then the nut must be rotated a ¼ turn back and after this the torque of the stem has to be tested.

The following table will provide a guide:

<b>DN</b>	40/ 1 ½"	50/ 2"	80/ 3"	100/ 4"	150/ 6"
<b>torque</b>	12 Nm	12 Nm	28 Nm	50 Nm	70 Nm

Fit ball (3) with groove to stem and place in the body.

Coat the trunnion (17) on bearing (13) with high temperature fat (OKS) in order to avoid cold welding.

Slide trunnion seal (20) and bearing (13) on the trunnion (17) and push it into body (1). Tighten Trunnion with hex. screw (15) in body (1).

Provide: Hauck	Approval: Roth	Date: 22.01.2016
Printed pages will not be updated		

 <b>KLINGER</b> Schöneberg	<b>Assembly and Repair Instructions</b>	page 5 of 6 release 0
	<b>INTEC K410- T-STD</b>	file: Montage-Reparatur- Anl INTE K410 T STD- EN_22012016

Don't shear or damage sealing- and bearing parts

Insert body seal (5) into body (1). Fit cap (2) and blind cap (22) carefully into body (1) without damaging the body seal (5). Coat hex. screw (18) on the thread with high temperature fat (OKS) in order to avoid cold welding.



In the case of valves stated as being oil- and grease-free assembly is performed without grease and without other auxiliary substances.

Tighten hexagon screws (18) crosswise gradually until the seal is evenly pressed out and cap (2) is metallicly on block with body (1).

### 4.3 Function, Strength and Tightness Test

After assembling the ball valve it must be checked whether it can move freely and whether the ball can turn unhampered. Finally the ball valve must be subjected to a strength and tightness test in accordance with EN12266 -1 Nr. P10 / P11 / P12.

### 4.4 Independent Conversion and Manufacture of Spare Parts

Conversion while changing the valve is only permissible after agreement and written declaration by the manufacturer. Original spare parts and accessories authorised by the manufacturer serve the purposes of safety. If other spare parts are used and consequences result KLINGER SCHÖNEBERG GmbH shall not assume liability.

### 4.5 Incorrect Operation

The operational reliability of the valve is only guaranteed if it is used correctly in accordance with the operating instructions for KLINGER SCHÖNEBERG ball valves. The limit value specified in the technical documentation may under no circumstances be undercut.

## 5 Dismantling

### 5.1 Precautionary Measures

In order to ensure that any product residue which has remained in the cavity of the valve cannot lead to risk to the staff performing the dismantling operation, appropriate protective clothing made of chemical and solvent resistant material is to be worn on the entire body and a resistant facial protection.

For reasons of caution dismantling should be performed via a catch tank. Any toxic gases or vapours must be extracted so that they may not reach personnel. This also applies to the final cleaning after dismantling has been completed.

The ball valves must be brought into a pressure-free state for the purposes of repair. For this purpose they should be brought into the semi-open position. It will similarly be necessary to perform cleaning on the inside and outside before dismantling. It is expedient to switch the ball several times during cleaning of the cavity.

Provide: Hauck	Approval: Roth	Date: 22.01.2016
Printed pages will not be updated		

	<b>Assembly and Repair Instructions</b>	page 6 of 6 release 0
	<b>INTEC K410- T-STD</b>	file: Montage-Reparatur- Anl INTE K410 T STD- EN_22012016

## 5.2 Preparing for Dismantling

Before dismantling, the body (1), the cap (2) and the parts of the ball valve should be marked so that the assembly positions can be understood later on.

## 5.3 Dismantling

For the purposes of dismantling the valve is tensioned again securely and safely in a suitable device. Loosening the hexagonal screws (18) will permit the cap (2) and blind cap (22) to be removed. Move the ball (3) to the open position (two flat along the flow direction). Press ball (3) into the body (1) with suitable device, to lift the pre-load from the ball seat (4). Therefore the trunnion can be removed. Remove the device and retain the ball.

After that the stem is dismantled. To unscrew the nut (14) you have to push a wedge into the slit of the nut. Using a wrench, the nut (14) can be screwed from the stem (6) in anti-clockwise direction. The stem can now be carefully pressed into the ball area. Secure the stem against falling down and damage.

The bearing (11) and below sealing parts (7) (8) can be removed from stem and upper sealing parts (9) (10) (12) can be removed from the cone.  
Then seat ring parts (4) (23) (21) (19) can be dismantled. Finally the body seal (5) is removed. Auxiliary agents will not usually be required.

## 5.4 Final Cleaning and Recording of Damage

After dismantling all parts are finally cleaned. The dismantled sealing parts are also to be included in cleaning so that they may be disposed of with problem.

The damage is then recorded.

Special attention must be paid to inside and outside damage to the body parts. The nature of the sealing surfaces at the ball seal, stem conduit, body sealing and the flange seals must be checked. The body parts are then jet-cleaned inside and out with glass pearls and cleaned mechanically if necessary and possible. For this purpose sealing areas must be covered up.

The valves are then to be cleaned anew and are then available for a further visual check for new assembly.

The stem is checked after visual checking for parallel running and traces of pressure of the two other flanges. Special attention must be directed at the perfect state of the sealing areas. Slight scratches can be removed with emery cloth. Damaged or twisted stems are replaced.

The cleaned ball is firstly visually checked. Deep scratches as well as other mechanical damage and chemical attack on the sealing surface as well as the running surface of the seal ring mean that the ball must be discarded. Similarly deformation in the area of the ball slit is inadmissible. All screws and sealing parts must be replaced during every repair.

Provide: Hauck	Approval: Roth	Date: 22.01.2016
Printed pages will not be updated		