	Assembly and Repair Instructions	page 1 of 5 release 0
	RK-Probball KH 2T M (NC)	file:

Assembly and Repair Instructions for KLINGER SCHÖNEBERG Ball Valves,
Type RK-Probball KH 2T M (NC)

Table of Contents

1	Validity	2
2	General Remarks.....	2
3	Construction and Components of the RK-Probball KH 2T M (NC).....	3
4	Assembly of the RK-Probball KH 2T M (NC)	4
4.1	Preparing for Assembly	4
4.2	Assembling the valve.....	4
4.3	Function, Strength and Tightness Test.....	4
4.4	Independent Conversion and Manufacture of Spare Parts.....	4
4.5	Incorrect Operation.....	4
5	Dismantling of the RK-Probball KH 2T M (NC)	5
5.1	Precautionary Measures.....	5
5.2	Preparing for Dismantling	5
5.3	Dismantling.....	5
5.4	Check of the Parts.....	5

provide: BNi	approval:	date: 29.05.2008
printed pages will not be updated		

	Assembly and Repair Instructions	page 2 of 5 release 0
	RK-Probball KH 2T M (NC)	file:

1 Validity

These Assembly and Repair Instructions are applicable to the type series listed below:

RK-Probball KH 2T M (NC)

2 General Remarks

These Assembly and Repair Instructions are designed to provide assistance in assembling, servicing and repairing the ball valve RK-Probball KH 2T M (NC).



The valves may only be dismantled and taken apart by skilled personnel acquainted with the assembly, commissioning and operation of this product.

Trained personnel within the meaning of these Assembly and Repair Instructions are individuals who are able to assess the work which they have been entrusted and to recognise possible risks in view of their special training, their know-how and experience and their knowledge of the pertinent standards.

These instructions as well as the **Operating Instructions for KLINGER SCHÖNEBERG Ball Valves** must be observed. KLINGER SCHÖNEBERG GmbH shall not assume no liability for damage or interruptions to operation arising from incorrect handling or failure to observe these Repair Instructions.

provide: BNi	approval:	date: 29.05.2008
printed pages will not be updated		

3 Construction and Components RK-Proball KH 2T M (NC)

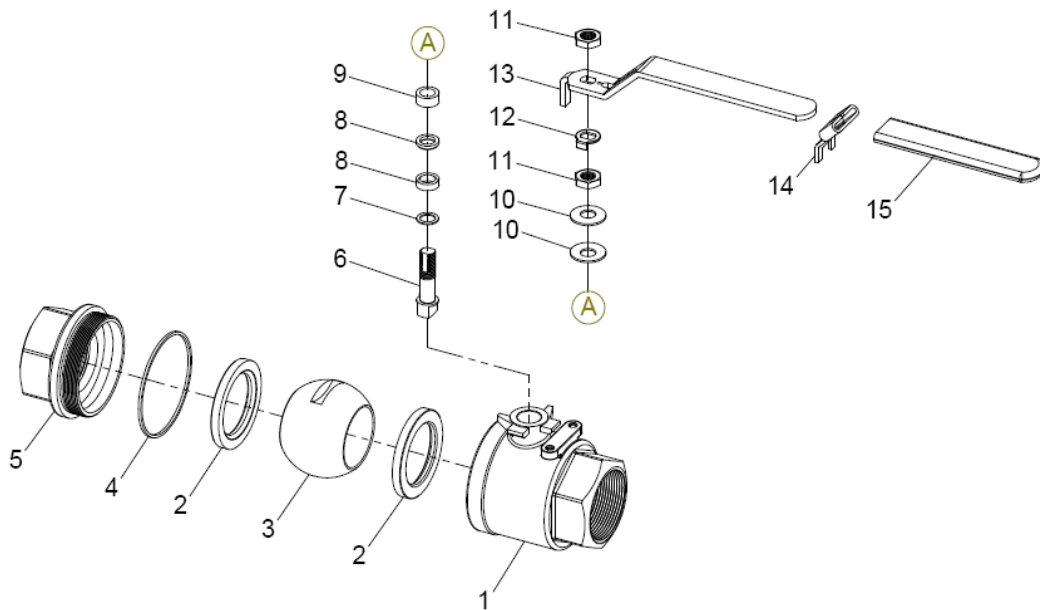

Pos.	Part
1	body
2	seat
3	ball
4	body seal
5	cap
6	stem
7	thrust washer
8	stem packing
9	gland ring
10	belleville disc

Pos.	Part
11	stem nut
12	nut stopper
13	handle
14	safety spring locking device
15	insulation cover

	Assembly and Repair Instructions	page 4 of 5 release 0
	RK-Probball KH 2T M (NC)	file:

4 Assembly of the RK-Probball KH 2T M (NC)

4.1 Preparing for Assembly

All parts must be prepared to assemble the ball valve, i.e. the parts are carefully cleaned and laid on a soft base (rubber mat or similar).

It must be considered that the plastic parts are almost always soft and very sensitive and that in particular the sealing surfaces may not be damaged.

4.2 Assembling the Valve

The body must be tensioned securely and safely in a suitable device; free access to the cavity and stem must be guaranteed.

- the thrust washer (7) must be placed upon the stem (6)
- the stem (6) must be inserted from the body side into the body (1)
- the stem packing (8) must be placed upon the stem (6)
- the gland ring (9) and belleville disc (10) must be placed upon the stem (6)
- screw the stem (6) with the stem nut (11) (the stem must be locked)
- insert the seat (2) and the ball (3) into the body (1)
- insert the seat (2) and the body seal (4) into the cap (5)
- screw the cap (5) with the body (1) and tighten
- the nut stopper (12) and the handle (13) must be placed from the stem (6) top and tighten the handle (13) with the stem nut (11)
- put it back to the ball valve completely into the pipe

4.3 Function, Strength and Tightness Test

After assembling the ball valve it must be checked whether it can move freely and whether the ball can turn unhampered. Finally the ball valve must be subjected to a strength and tightness test in accordance with EN12266 -1 Nr. P10 / P11 / P12.

4.4 Independent Conversion and Manufacture of Spare Parts

Conversion while changing the valve is only permissible after agreement and written declaration by the manufacturer. Original spare parts and accessories authorised by the manufacturer serve the purposes of safety. If other spare parts are used and consequences result KLINGER SCHÖNEBERG GmbH shall not assume liability.

4.5 Incorrect Operation

The operational reliability of the valve is only guaranteed if it is used correctly in accordance with the operating instructions for KLINGER SCHÖNEBERG ball valves. The limit value specified in the technical documentation may under no circumstances be undercut.

provide: BNI	approval:	date: 29.05.2008
printed pages will not be updated		

	Assembly and Repair Instructions	page 5 of 5 release 0
	RK-Probball KH 2T M (NC)	file:

5 Dismantling of the RK-Probball KH 2T M (NC)

5.1 Precautionary Measures

In order to ensure that any product residue which has remained in the cavity of the valve cannot lead to risk to the staff performing the dismantling operation, appropriate protective clothing made of chemical and solvent resistant material is to be worn on the entire body and a resistant facial protection.

For reasons of caution dismantling should be performed via a catch tank. Any toxic gases or vapours must be extracted so that they may not reach personnel. This also applies to the final cleaning after dismantling has been completed.

The ball valves must be brought into a pressure-free state for the purposes of repair. For this purpose they should be brought into the semi-open position. It will similarly be necessary to perform cleaning on the inside and outside before dismantling. It is expedient to switch the ball several times during cleaning of the cavity.

5.2 Preparing for Dismantling

Before dismantling, the body (1), the cap (5) and the parts of the ball valve should be marked so that the assembly positions can be understood later on.

5.3 Dismantling

- before starting with the dismantling, the ball valve must be closed. Please take note, that no remaining pressure is on the pipe
- remove the ball valve completely out of the pipe
- unscrew the cap (5) and remove the body seal (4) and seat (2)
- take the ball (3) and the seat (2) out of the body (1)
- unscrew the stem nut (11) and remove the handle (13) and nut stopper (12)
- unscrew the stem nut (11) and remove the belleville disc (10) and gland ring (9)
- please take care, that the stem (6) is locked from the body (1) side
- press the stem (6) from the top into the body (1) and remove it
- remove the stem packing (8) from the body (1) and thrust washer (7) from the stem (6)

5.4 Check of the parts

If necessary, all single parts must be cleaned after the dismantling.

Check of the ball: Any defect (scratches, grooves, abrasion, corrosion etc.) at the surface, particularly in the sealing area can be a cause of leakage. If a fault will be noticed, the ball must be replaced.

Further sealing parts: [body seal (4), stem packing (8), seat (2), thrust washer (7)]. All these parts must be replaced in every case. A multiple use of one of these parts is not permitted. Please use always original spare parts.

Stem: After the cleaning, the stem must be checked on rust, particularly in the thread area and must be replaced if necessary.

Body and its parts: The body and its parts have to be checked on defects at the surface. In doubt cases or when required, a surface crack test (dye penetration test) is to be carried out. All other parts must be checked on mechanical damages and to be replaced if necessary.

provide: BNi	approval:	date: 29.05.2008
printed pages will not be updated		