

Data sheet quadax® - lug type butterfly valve



body details

butterfly valve:	bare shaft
pressure range:	0-913 psi
nominal size:	2" -70"
connection:	flange
body materials:	carbon steel, stainless steel, special material (duplex, inconel, bronze)
valve seat materials:	inconel, others on request
seal materials:	stainless steel with or without laminated graphite, inconel, PTFE



The body materials listed above are in contact with the media.

details needed

- size
- pipe connection
- operating pressure
- flow rate
- Δp
- closing time
- media
- process temperature
- ambient temperature



The valves' technical design is based on media and application requirements. This can lead to deviations from the general specifications shown on the data sheet with regards to the design, sealing materials and characteristics.



If order or application specifications are incomplete or imprecise there is the potential for an incorrect technical design of the valve for the required application. As a consequence, the physical and / or chemical properties of the materials or seals used, may not be suitable for the intended application.

general specifications

ports	flange	ANSI 150 / 300 / 600
function		depending upon actuator
pressure range	body pressure	0 to 913 psi
	Δp standard shaft	754 psi in both directions
Cv value	gal/min	see table
leakage rate		zero-leakage per API 6D and API 598 resilient in both direction; fire-safe per API 607 6th edition
flow direction		indicated by arrow on body of valve
switching time		depending upon actuator
process- and outside temperature	standard	+14°F to +842°F
	with special materials	-454°F to +1472°F
limit switches		depending upon actuator
approvals		PED / Fire safe / BAM / TA Luft / ATEX
weight	lbs	see table
additional equipment		upon request

Cv-curve

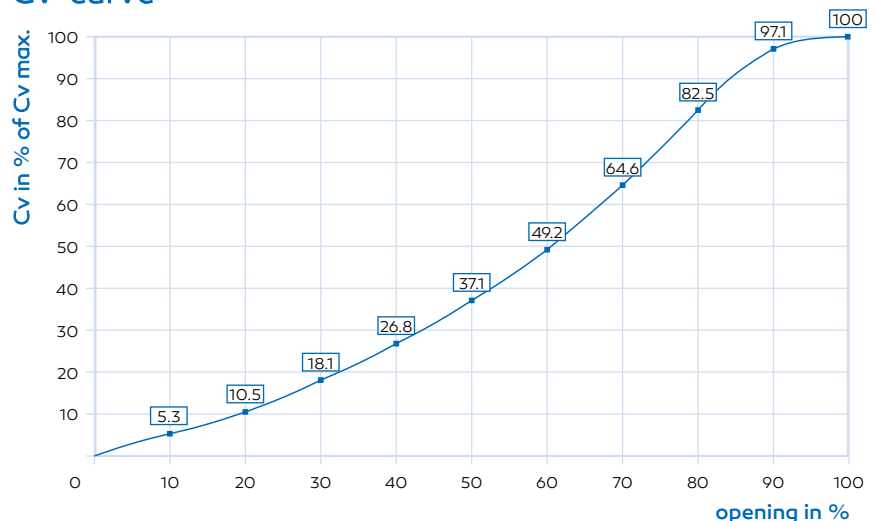

quadax valves inc.
 1518 Grundy's Lane
 Bristol, PA 19007, USA
 Email: sales@quadaxvalves.com
 Phone: 855-578-2329

Data sheet quadax® - lug type butterfly valve

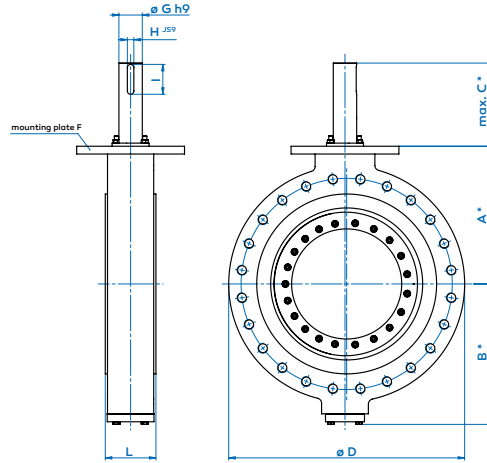

* dimensions for trim X only

Dimensions

size	(inch)	2	2½	3	4	5	6	8	10	12	14	16	18	20	24	28	30	32	36	40	
pipe cl to mounting plate	A	4.13	5.04	5.04	6.38	7.48	7.99	9.45	10.98	12.01	12.80	15.16	15.94	17.32	20.87	24.80	24.80	27.56	32.68	36.22	
pipe cl to cover screws	B	4.17	5.08	5.08	6.22	7.32	8.03	9.49	11.06	12.09	13.11	15.08	15.87	17.36	21.30	25.31	25.31	28.07	32.91	36.46	
bare shaft length for direct mounting	C	3.74	3.74	3.74	4.92	5.31	5.71	7.09	7.09	7.09	11.02	11.38	11.81	12.60	12.60	14.45	14.45	14.45	15.67	15.67	
bare shaft length for adapter	C	2.01	2.01	2.01	2.68	2.68	2.68	3.35	3.35	3.35	6.81	6.69	6.69	6.69	6.69	8.27	-	-	-	-	
flange diameter	ANSI 150	D	6.50	7.48	7.48	9.06	-	11.02	13.86	15.94	19.09	21.65	23.23	25.20	27.56	32.09	36.50	38.74	42.72	45.98	50.79
	ANSI 300	D	6.50	8.27	8.27	10.00	-	12.60	14.96	17.52	20.28	23.03	25.98	27.95	30.31	35.75	40.75	42.99	45.24	50	48.74
	ANSI 600	D	6.50	8.27	8.27	10.83	-	13.98	16.54	20	22.05	23.82	26.97	29.33	32.09	37.01	42.24	44.49	47.01	51.77	51.97
mounting plate F ISO 5211	(others on re-request)	F	F07	F70	F07	F10	F12	F14	F16	F16	F25	F30	F30	F35	F35	F40	F40	F40	F48	F48	
trim A	290 psi max.	G	-	-	-	-	-	-	-	1.57	1.77	1.97	2.17	2.17	2.76	3.54	3.54	3.94	4.33	4.72	
		H	-	-	-	-	-	-	-	0.47	0.55	0.55	0.63	0.63	0.79	0.98	0.98	1.10	1.26	1.26	
		I	-	-	-	-	-	-	-	1.77	2.36	2.36	3.15	3.15	3.54	4.53	4.53	4.92	5.51	6.30	
trim X (standard)	754 psi max.	G	0.55	0.55	0.71	0.79	0.87	1.26	1.26	1.57	1.77	2.17	2.56	2.76	2.95	3.54	4.33	4.33	5.12	5.91	6.30
		H	0.20	0.22	0.24	0.24	0.24	0.39	0.39	0.47	0.55	0.63	0.71	0.79	0.79	0.98	1.26	1.26	1.26	1.42	1.57
		I	0.98	1.10	1.10	1.10	1.57	1.57	1.57	1.77	2.36	3.15	3.46	3.54	3.54	4.53	5.51	5.51	7.09	7.09	7.87
API 609	ANSI 150	L	1.69	1.69	1.89	2.13	-	2.24	2.52	2.80	3.19	3.62	4.02	4.49	5.50	6.06	-	-	-	-	-
	ANSI 300	L	1.69	1.69	1.89	2.13	-	2.32	2.87	3.27	3.62	4.61	5.24	5.87	6.26	7.13	-	-	-	-	-
	ANSI 600	L	1.69	2.13	2.13	2.52	-	3.07	4.02	4.61	5.51	6.10	7.01	7.87	8.50	9.13	-	-	-	-	-
Cv-value (gal/min)	trim A	Δp max. 290 psi	-	-	-	-	-	-	-	4462	6370	9237	12483	15024	24013	29620	37978	42003	55308	65269	
	trim X	Δp max. 754 psi	44	137	137	300	486	760	1680	2850	4314	5953	8513	11612	14091	22387	26838	31702	38771	50250	59765
weight (standard)	(approx. lbs)	18	35	35	49	71	86	150	282	331	487	703	769	1008	1576	2242	2652	2945	3845	5439	