



MANIFOLD KLINGER®

Steam tracing systems are used in industry whenever there is a need to heat pipes that carries fluids that solidify at room temperature. In specific cases, a large number of branches lines is necessary to carry out this work, thus, there is also a need for many pipe fittings and small diameter valves which, in addition to the installation and maintenance difficulties, are also potential leak points.

In order to make these systems more compact, safer and more efficient, KLINGER developed the KLINGER® Manifold that join in a single body combinations of 4, 8 or even 12 valves with an exclusive piston sealing system that provide leak-tight shut off, long service life and easy and low-cost maintenance.

The KLINGER® Manifolds can be used both at the inlet to the tracing system, where steam is distributed to the various branch lines, as well as in the collection of condensate, where the discharge of the traps is connected to the valves of the manifold which, in turn, is connected the condensate return line.

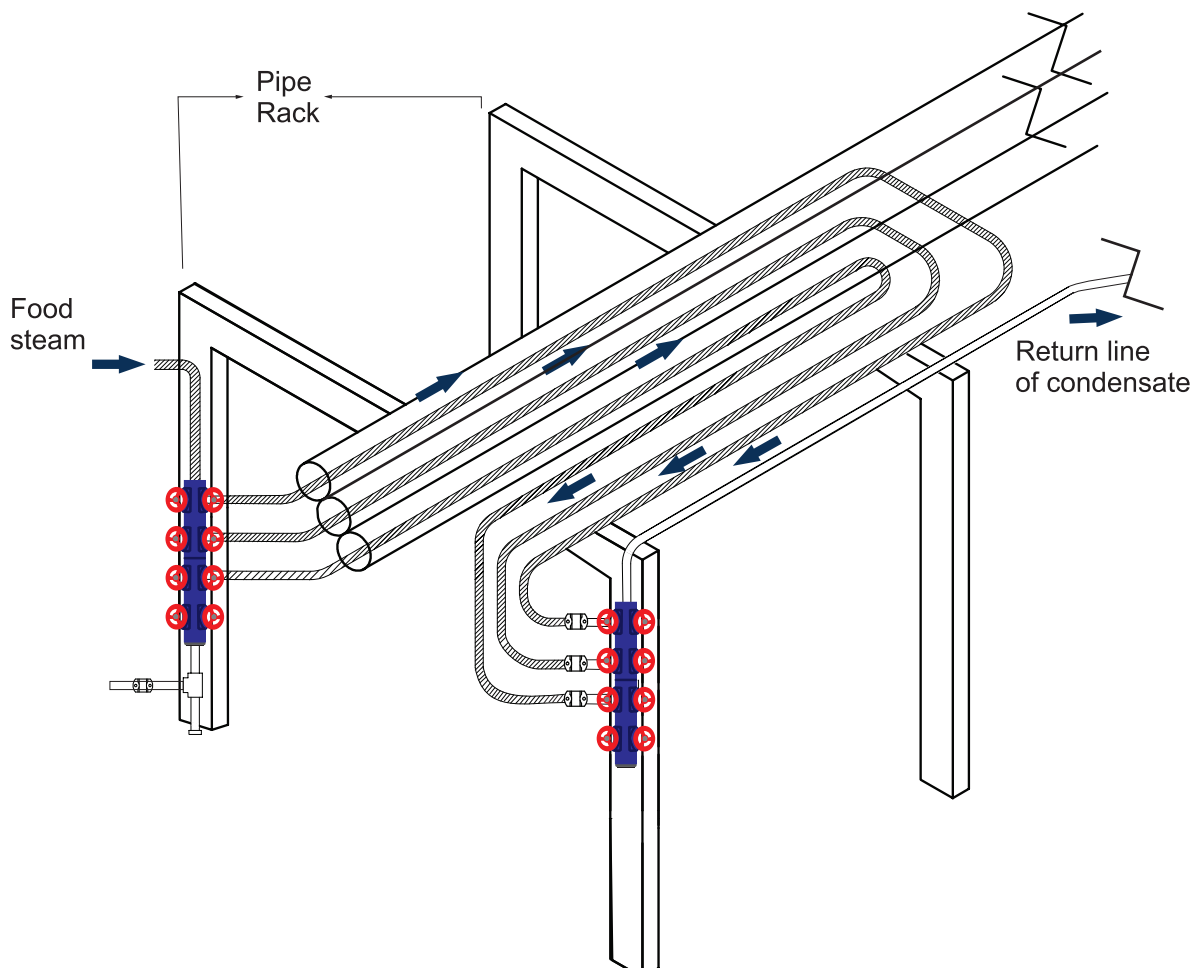

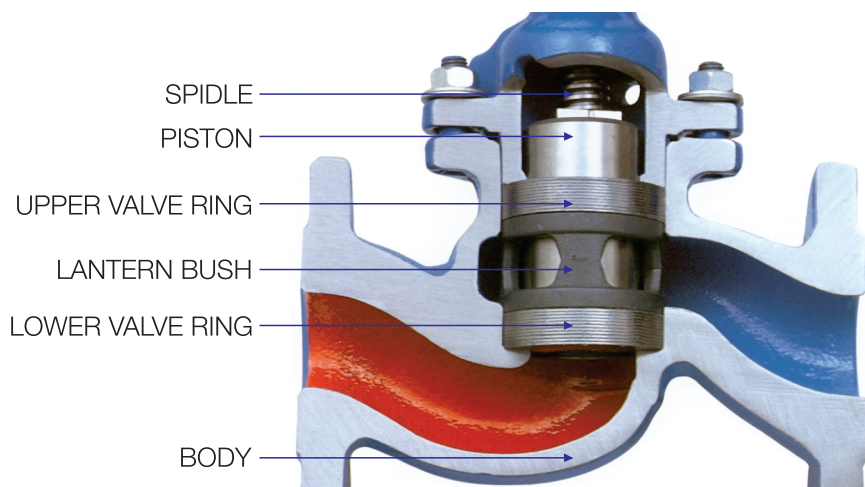

A stainless steel piston enclosed by two valve rings makes up the sealing element. The upper valve ring provides the stem seal, while the lower valve ring seals the passage.

This contact between the piston and the upper ring replaces the packings and bonnet seals - items found in conventional valves.

KLINGER piston valves have proven performance for decades of use in the industry in applications such as steam and superheated water, Heat transfer oils, chemicals and miscellaneous types of gases (e.g. Oxygen, Hydrogen, Nitrogen, etc.)

Direction of flow for steam distribution.

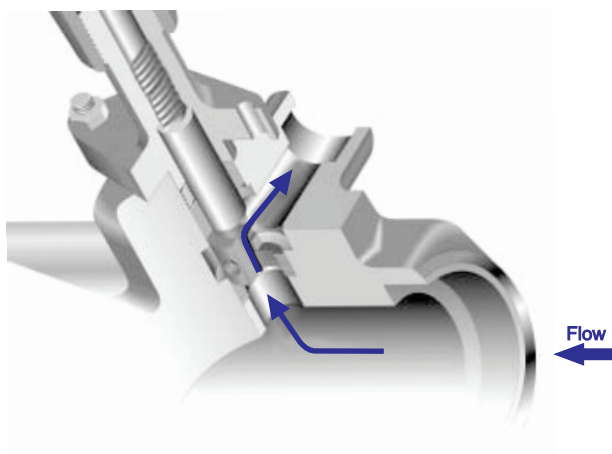

Direction of flow for collection of count.

